

VD TYPE VOLUME DAMPER

1. Features :

The volume dampers are used for adjusting air volume. There are two control modes: manual control and electrical control. The manual control mode adopt worm gearing, and electrical control mode adopt import electrical actuator. The volume damper could be controlled air volume by adjusting the angle of the actuator.

2. Outline Drawing

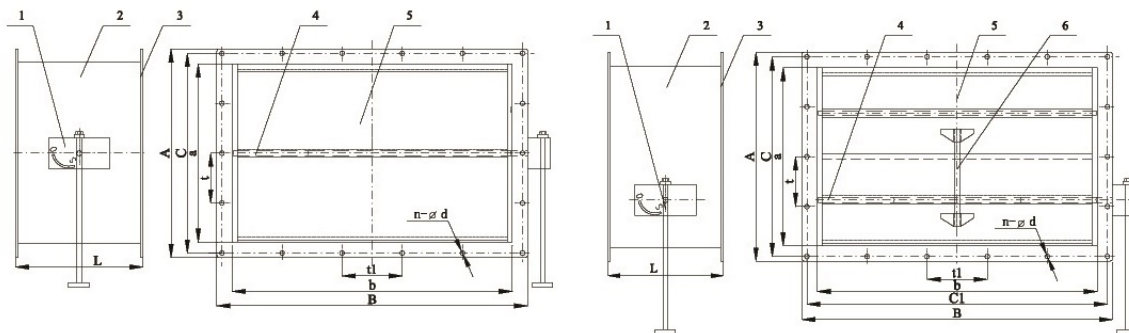

1.actuator 2.valve body 3.flange 4.main axle 5.valve plate

1.actuator 2.valve body 3.flange 4.main axle 5.valve plate 6.linkage

1 (Rectangular single blade)

2 (Rectangular multi-blades)

3. Type & Parameter

	axb	L	Flange size
VD-axb	100x100~1000x1000	>250	GB1561-79 According to GB1561-79

Note: Flange size of all fire dampers could be fabricated according to user's requirement.

4. Our VD damper can be cranked out circular single blade or multi-blades, and the control type can be selected electrical or manual.